



TROLLEY 2-LEVEL EXTRA HEAVY-DUTY WITH LOCKABLE TOP

MODEL NO: **wolf-a124**

Thank you for purchasing a wlf tech product. Manufactured to a high standard, this product will, if used according to these instructions, and properly maintained, give you years of trouble free performance.

IMPORTANT: PLEASE READ THESE INSTRUCTIONS CAREFULLY. NOTE THE SAFE OPERATIONAL REQUIREMENTS, WARNINGS & CAUTIONS. USE THE PRODUCT CORRECTLY AND WITH CARE FOR THE PURPOSE FOR WHICH IT IS INTENDED. FAILURE TO DO SO MAY CAUSE DAMAGE AND/OR PERSONAL INJURY AND WILL INVALIDATE THE WARRANTY. KEEP THESE INSTRUCTIONS SAFE FOR FUTURE USE.



Refer to instructions

1. SAFETY

1.1. GENERAL SAFETY

- WARNING!** Ensure Health & Safety, local authority, and general workshop practice regulations are adhered to when using this trolley.
- ✓ Always load evenly with the centre of gravity of the load as near centre of the trolley as possible.
- ✗ DO NOT overload the trolley - see section 2.
- ✓ Use the trolley in a suitable work area.
- ✓ Keep the work area clean, uncluttered and ensure there is adequate lighting.
- ✓ Keep the trolley clean and tidy in accordance with good workshop practice.
- ✗ DO NOT use the trolley for any purpose other than that for which it is designed.
- ✗ DO NOT stand on the trolley, use it as a ladder or allow others to ride on the trolley.
- ✓ Use the wheel locks to prevent the trolley from inadvertently moving.
- ✗ DO NOT leave unattended, especially when loaded, unless the wheels are locked, chocked or the trolley otherwise secured.
- ✗ DO NOT use trolley on uneven ground and do not run over curbs or steps - use a ramp.
- ✗ DO NOT use trolley if any part is significantly damaged, paying particular attention to the wheels.
- ✓ Keep children and unauthorised persons away from the work area.



2. INTRODUCTION

Garage or workshop trolley with a total capacity of 80kg. Upper shelf has liner and lockable top, lower shelf may be installed base down or base up to give either tool and component security or unobstructed access. Four large castors, two braked.

3. CONTENTS

Carefully unpack the product and check the contents against the diagram and parts list below. Should any items be missing or damaged contact your Sealey stockist.

4. ASSEMBLY

- 4.1. Mount lockable top tray (2) to the upper hole in the end frames (3) and loosely fix with four M6 x 32mm bolts (1). Make sure the dished holes on the end frames are facing outwards.
- 4.2. Mount the other tray (11) to the middle lower holes in the end frames (3) and loosely fix with M6 x 32mm bolts (1). Tighten all bolts (1).
- 4.3. Turn the trolley over, install castors (4 & 5) into the bottom of the end frames and fix with the M6 x 12mm bolts (6).
- 4.4. Turn the trolley upright. The trolley is ready to use.

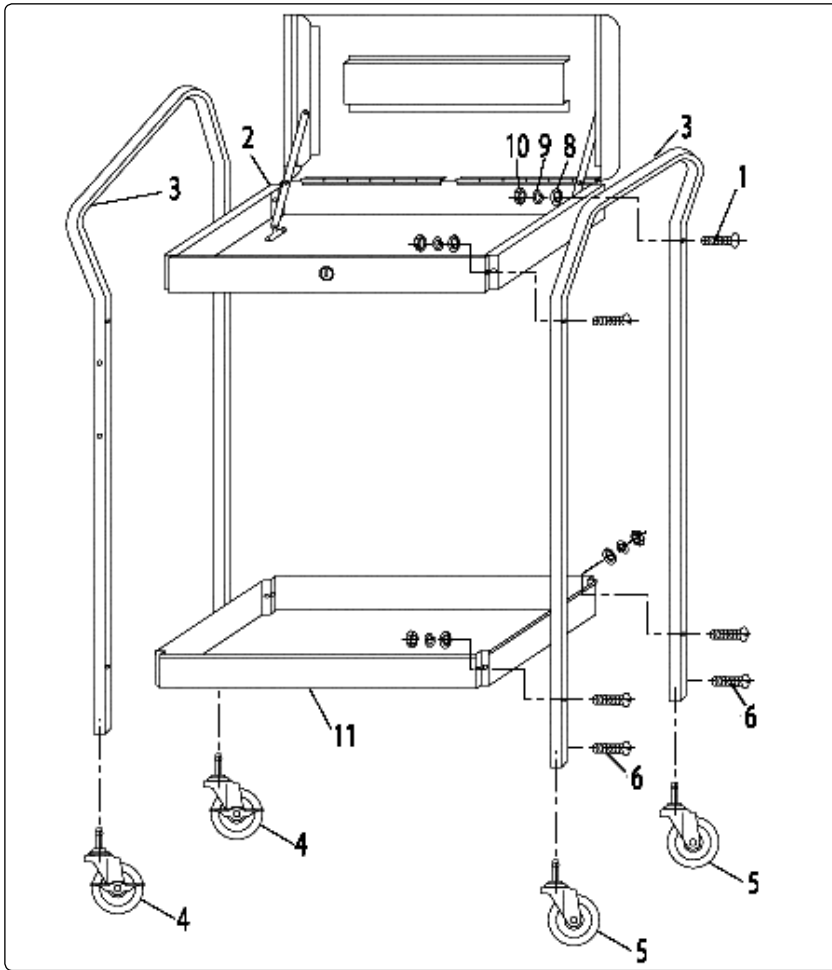

5. PARTS

| Item | Part No: | Description |
|------|------------|------------------------|
| 1 | CX1042D.01 | BOLT M6 x 32mm |
| 2 | CX1042D.02 | TRAY |
| 3 | CX1042D.03 | HANDLE |
| 4 | CX1042D.04 | CASTOR WHEEL c/w BRAKE |
| 5 | CX1042D.05 | CASTOR WHEEL |
| 6 | CX1042D.06 | BOLT M6 x 12mm |
| 8 | CX1042D.08 | WASHER |
| 9 | CX1042D.09 | SPRING WASHER |
| 10 | CX1042D.10 | NUT |



www.wolf-tech.ir

شرکت ولف تکنولوژی

Parts support is available for this product. To obtain a parts listing and/or diagram, please log on to www.wolf-tech.ir, email www.wolf-tech.ir or telephone 0912-2617264



Environmental Protection

Recycle unwanted materials instead of disposing of them as waste. All tools, accessories and packaging should be sorted, taken to a recycling centre and disposed of in a manner which is compatible with the environment. When the product becomes completely unserviceable and requires disposal, drain off any fluids (if applicable) into approved containers and dispose of the product and the fluids according to local regulations.

NOTE: It is our policy to continually improve products and as such we reserve the right to alter data, specifications and component parts without prior notice.

IMPORTANT: No liability is accepted for incorrect use of this product.

WARRANTY: Guarantee is 12 months from purchase date, proof of which will be required for any claim.



☎ 09122617264

🌐 www.wolf-tech.ir

📠 09395728132

✉ admin@wolf-tech.ir