



Thank you for purchasing a wolf product. Manufactured to a high standard, this product will, if used according to these instructions and maintained properly, give you years of trouble free performance.

IMPORTANT: PLEASE READ THESE INSTRUCTIONS CAREFULLY. NOTE THE SAFE OPERATIONAL REQUIREMENTS, WARNINGS & CAUTIONS. USE THE PRODUCT CORRECTLY AND WITH CARE FOR THE PURPOSE FOR WHICH IT IS INTENDED. FAILURE TO DO SO MAY CAUSE DAMAGE AND/OR PERSONAL INJURY AND WILL INVALIDATE THE WARRANTY. KEEP THESE INSTRUCTIONS SAFE FOR FUTURE USE.



Refer to Instruction Manual

1. SAFETY

- WARNING!** Use workstation on level and solid ground, preferably concrete.
- ✓ Locate workstation in a suitable working area.
- ✓ Keep the work area clean, uncluttered and ensure there is adequate lighting.
- ✓ Keep the workstation clean and tidy in accordance with good workshop practice.
- ✓ Keep children and unauthorised persons away from working area.
- ✓ Ensure that fixings have been securely tightened before use.
- ✗ **DO NOT** use the workstation for any purpose other than that for which it is designed.
- ✗ **DO NOT** stand on the frame or attempt to ride on it.
- ✗ **DO NOT** attempt to transport heavy loads on the workstation.

2. INTRODUCTION

Table is fully adjustable in height. Features four-section table, one large for main workpiece and three equal sized smaller sections for accessories. Rubber lining on the table helps prevent damage to the unit and workpiece. Suitable for use in workshops and warehouses. Supplied with four castor wheels.

3. SPECIFICATION

Model No:**AP200**
 Minimum height:890mm
 Maximum height:1190mm
 Table size (W & D):730 x 505mm
 Capacity:25kg

4. ASSEMBLY

Refer to fig.1.

- 4.1. Bolt front wheel frame (10) to joining frame (9). Bolt rear wheel frame (12) to joining frame (9).
- 4.2. Bolt table top base assembly (8) to joining frame (9).
- 4.3. Screw wheels into the bottom of both wheel frames (10) and (12).
- 4.4. Bolt table top mounting frame (6) to table top (3) using spring washer (5) and table top mounting bolt (4). **Note:** table top (3) and table top mounting frame (6) will only fit together one way.
- 4.5. Insert the table top mounting frame (6) into table top base assembly (8) so that the table top is centred directly over the longest width of the wheels, see fig.2.
- 4.6. Screw in table top adjusting screw (7).

5. OPERATION

- WARNING! DO NOT** extend the table beyond the extension warning line located on the table pole.
- 5.1. To adjust the height of the workstation firstly support the table top to prevent it from dropping, then turn the adjusting screw (7) anticlockwise to loosen it.
- 5.2. When positioning the table next to or over painted or 'valuable' surfaces ensure they are covered by protective non-scratch covers.

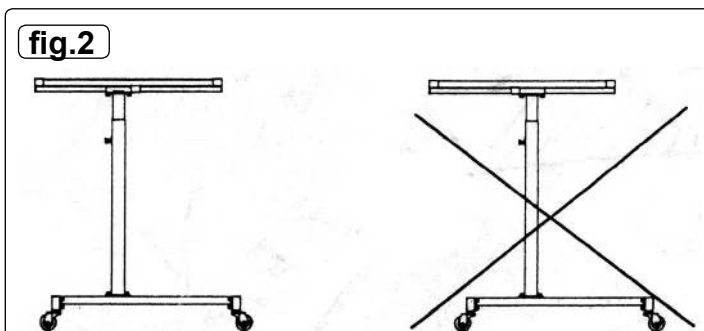
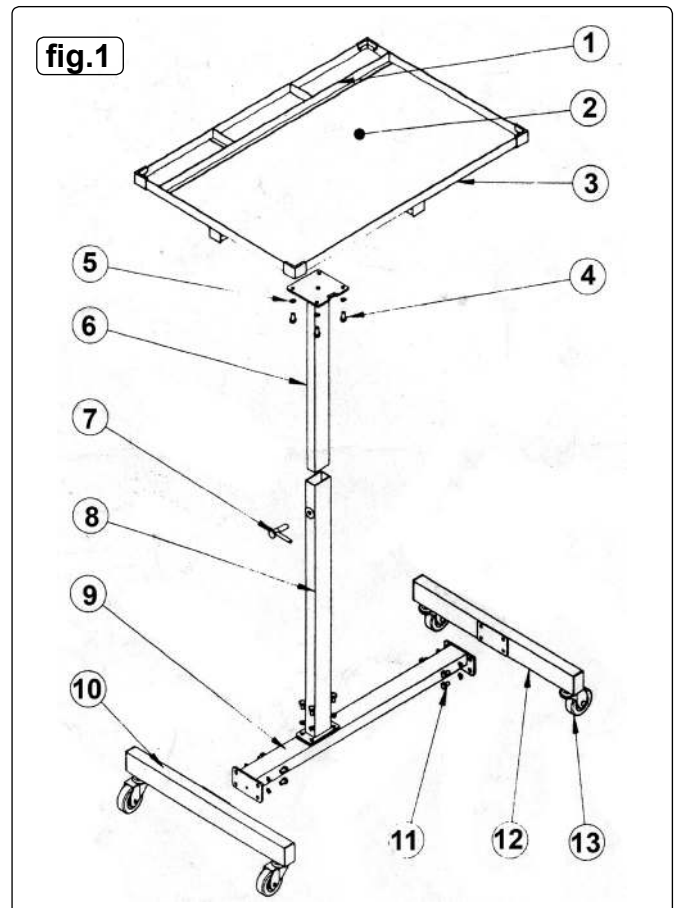



Environmental Protection



Recycle unwanted materials instead of disposing of them as waste. All tools, accessories and packaging should be sorted, taken to a recycling centre and disposed of in a manner which is compatible with the environment. When the product becomes completely unserviceable and requires disposal, dispose of it according to local regulations.

NOTE: It is our policy to improve products continually and as such we reserve the right to alter data, specifications and component parts without prior notice.

IMPORTANT: No liability is accepted for incorrect use of this product.

WARRANTY: Guarantee is 12 months from purchase date, proof of which will be required for any claim.



www.wolf-tech.ir
شركت ولف تكنولوژی



09122617264



www.wolf-tech.ir

admin@wolf-tech.ir